



Commercial HVAC 101

Typical System Components & Cleaning Techniques



Copyright © 2016 NADCA. All Rights Reserved.
No part of this publication may be reproduced or distributed by any means, electronic or mechanical, including photocopy, recording, or any other information storage and retrieval system, without prior written consent from the publisher.



Presenter



Robert Rizen is the General Manager of Iaq & Restoration services. He has been involved with air conveyance cleaning since 1989 as well as full service restoration operations.

*Email: Robert.rizen@gmail.com
Cell: 314-518-1681
<https://www.linkedin.com/in/robertrizen>*

Robert Rizen



Disclaimer

This presentation is not intended to be a comprehensive program covering all aspects of this topic. All technicians are encouraged to read and follow all applicable standards, codes and regulations related to this topic.

- ✓ It is the responsibility of each individual contractor to follow local building codes and licensing requirements and to work safely in accordance with OSHA guidelines.
- ✓ It is the contractor's responsibility to take proper precautions on each project to prevent cross contamination. Always take the health and safety of the building occupants into consideration before you conduct any cleaning procedures.
- ✓ All of the following tips are only general tips. They do not cover every situation and it is your responsibility to adapt these tips to the individual system you are working on.
- ✓ The Instructor is not responsible in any way for the work you perform after viewing this slide show. You are responsible for your own work.
- ✓ The views and opinions following are the instructors opinions and not necessarily the official position of the National Air Duct Cleaners Association.





Commercial HVAC 101

Supplemental Materials

This session covers key points but not every detail. The tips & techniques presented are for cleaning & restoration procedures. For a full understanding of this topic, attendees are encouraged to review additional materials including:

NADCA Standard ACR





What We'll Learn

- Types of HVAC Systems
- Typical Components
- Tips for Cleaning These Systems
- Cleaning Requirements



Commercial HVAC 101

Section 1: Types of Systems

Typical commercial system types:

- Variable Air Volume
- Constant Volume
- Dual Duct
- Single Zone
- Multiple Zone



Commercial HVAC 101

Section 1: Types of Systems

Key Terms

Variable Air Volume (VAV) System:

Maintains thermal comfort by **varying the amount of heated or cooled air** delivered to each space.



Commercial HVAC 101

Section 1: Types of Systems - VAV

VAV AIR CONDITIONING SYSTEM

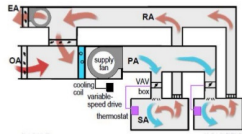



Commercial HVAC 101

Section 1: Types of Systems - VAV

Variable Air Volume Control Boxes



Dampers are the main component to be concerned with during cleaning.



Commercial HVAC 101

Section 1: Types of Systems - VAV

Variable Air Volume Systems

- Spiral duct from AHU to VAV.
- Accessibility to clean VAV boxes plus the clean fan & coil.
- Use slot diffusers or troffers which creates a higher level of difficulty for cleaning or coating.





Commercial HVAC 101

Section 1: Types of Systems

Key Terms

Constant Volume System:

Delivers **constant airflow** to each space.
Changes in temperature are made by heating or cooling the air or switching the AHU on and off.



Commercial HVAC 101

Section 1: Types of Systems - CV

Constant Volume Systems

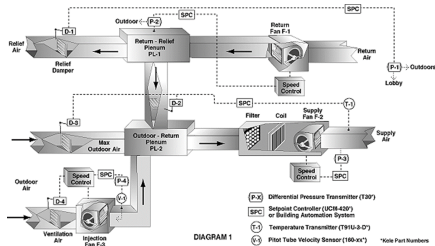



Commercial HVAC 101

Section 1: Types of Systems - CV

Constant Volume Systems

- Takes minimal amount of equipment to clean.
- Once you get cabinet panels off, accessibility can still be tricky.
- Older systems can be difficult to disassemble and reassemble.

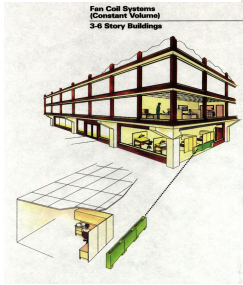



Commercial HVAC 101

Section 1: Types of Systems

Key Terms

Dual Duct:

A fan discharges air which is directed through the cooling coil and/or the heating coil. There are **two separate ducts that feed hot and cold air** to the same space.





Commercial HVAC 101

Section 1: Types of Systems – Dual Duct

Dual Duct Systems

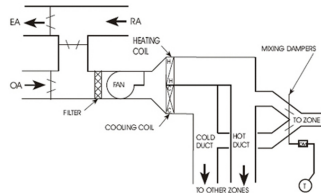
Found in commercial buildings such as hospitals and government buildings. Can be twice as many ducts.





Commercial HVAC 101

Section 1: Types of Systems – Dual Duct

Two Fan Dual Duct Variable Air Volume (VAV) Systems
1-2 Story Buildings



- Spiral duct from AHU to VAV.
- Twice as much supply duct from AHU to VAV's

Accessibility to clean VAV boxes & coil.
Use slot diffusers or troffers which creates a higher level of difficulty for cleaning or coating.



Commercial HVAC 101

Section 1: Types of Systems – Single Zone

Supplies air at a constant temperature to one complete zone, or area, of a building or to the entire structure all at once. **(Has one thermostat)**

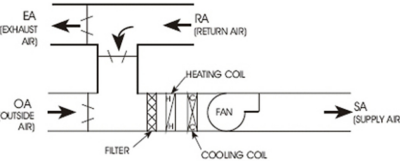



Commercial HVAC 101

Section 1: Types of Systems – Multi Zone

Has more than one thermostat and is characterized primarily by two or more supply ducts emanating from the HVAC unit.

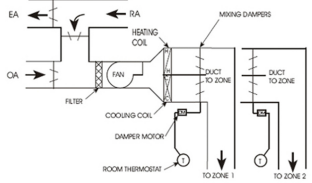



Commercial HVAC 101

Section 1: Types of Systems – Multi Zone

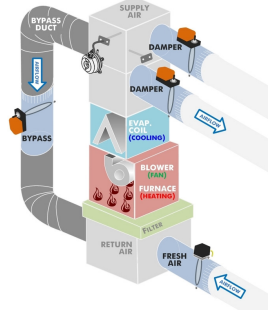



Commercial HVAC 101

Section 1: Types of Systems

Daikin Style Mini Split



- Integrated supply and return air
- Contains fan, coils, drain pan
- Complete dis assembly is needed for complete cleaning
- Found in hospitals and schools



Commercial HVAC 101

Section 2: HVAC Cleaning & Restoration Methods

- NADCA does not endorse or recommend any single method of cleaning or type of equipment.
- NADCA recommends the use of source removal methods and equipment designed to clean HVAC systems to the cleanliness levels specified in NADCA Standard ACR.
- Each different cleaning method has its advantages and disadvantages

TECHNICAL
NADCA
CONFERENCE

Commercial HVAC 101

Section 2: HVAC Cleaning & Restoration Methods

Cleaning Methods: Vacuum Collection



TECHNICAL
NADCA
CONFERENCE

Commercial HVAC 101

Section 2: HVAC Cleaning & Restoration Methods

Cleaning Methods: Vacuum Collection

A vacuum collection device alone will **not** get an HVAC system clean.

Methods and tools designed to agitate debris adhered to surfaces along with use of vacuum collection device(s), is required.

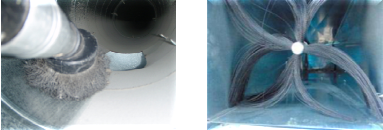

TECHNICAL
NADCA
CONFERENCE

Commercial HVAC 101

Section 2: HVAC Cleaning & Restoration Methods

Cleaning Methods: Brushing

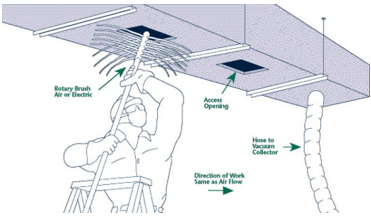

TECHNICAL NADCA CONFERENCE

Commercial HVAC 101

Section 2: HVAC Cleaning & Restoration Methods
Cleaning Methods: Air Washing

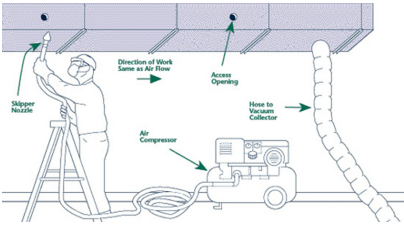

The diagram illustrates the air washing process. A technician on a ladder uses a skipper nozzle to clean an access opening in the ceiling. An air compressor is connected to the nozzle via a hose that leads to a vacuum collector. Labels include: Skipper Nozzle, Direction of Work Same as Air Flow, Access Opening, Hose to Vacuum Collector, and Air Compressor.

TECHNICAL NADCA CONFERENCE

Commercial HVAC 101

Section 2: HVAC Cleaning & Restoration Methods
Cleaning Methods: Air Washing

Whips, Rods, Blast Nozzles

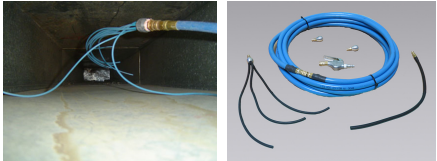

Two photographs showing cleaning tools. The left photo shows a blue whip with a nozzle. The right photo shows a blue rod with a nozzle and a black whip with a nozzle.

TECHNICAL NADCA CONFERENCE

Commercial HVAC 101

Section 2: HVAC Cleaning & Restoration Methods
Cleaning Methods: Contact Vacuuming

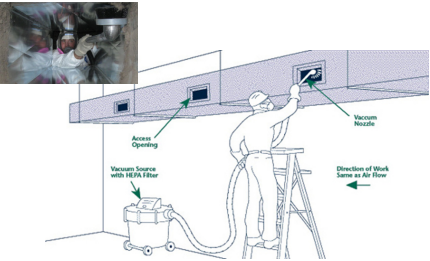

The diagram shows a technician on a ladder using a vacuum nozzle to clean an access opening in the ceiling. A vacuum source with a HEPA filter is connected to the nozzle via a hose. Labels include: Access Opening, Vacuum Nozzle, Vacuum Source with HEPA Filter, and Direction of Work Same as Air Flow.

TECHNICAL NADCA CONFERENCE



Commercial HVAC 101

Section 2: HVAC Cleaning & Restoration Methods

Cleaning Methods: Hand Washing

This procedure is just what its name implies- washing components by hand.

Involves hand tools such as brushes, sponges or damp cloths to wipe clean a designated area.

Liquids cannot be applied to porous components such as fibrous glass. Make sure that no chemical residues are left in the system during hand washing.

TECHNICAL NADCA CONFERENCE

Commercial HVAC 101

Section 2: HVAC Cleaning & Restoration Methods

Cleaning Methods: Power Washing

Power Washing

Power washing involves the use of mechanical equipment able to spray a jet of water onto a specific area.



Components frequently cleaned by power washing:

- Cooling and reheat coils
- Blower wheels, fans and their housings
- Evaporator and condensing coils
- Condensate drain pan
- Some types of filters
- Grilles, registers, and diffusers

TECHNICAL NADCA CONFERENCE

Commercial HVAC 101

Section 2: HVAC Cleaning & Restoration Methods

Why clean in this order?



Reduces likelihood of cleaned portions becoming re-contaminated.

Commercial HVAC 101

Q&A

You have Questions We have Answers

TECHNICAL NADCA CONFERENCE

Commercial HVAC 101

Section 3: Component Cleaning

FIGURE 8-1: Typical HVAC System Components

TECHNICAL NADCA CONFERENCE

Commercial HVAC 101

Section 3: Component Cleaning

TECHNICAL
NADCA
CONFERENCE

Commercial HVAC 101

Section 3: Component Cleaning

Air Handling Unit (AHU)

Air handling units, terminal units (VAV, Dual duct boxes, etc.), blowers and exhaust fans:
Ensure that supply, return, and exhaust fans and blowers are thoroughly cleaned. Areas to be cleaned include:

- ✓ Fan & Fan Housings
- ✓ Fan compartments
- ✓ Plenums (except ceiling supply and return plenums)
- ✓ Coil sets
- ✓ Blades or Vanes
- ✓ Shafts
- ✓ Baffles
- ✓ Dampers
- ✓ Drive assemblies



TECHNICAL
NADCA
CONFERENCE

Commercial HVAC 101

Section 3: Component Cleaning

AHU Types



Small RTU



Built in place AHU

TECHNICAL
NADCA
CONFERENCE

Commercial HVAC 101

Section 3: Component Cleaning

AHU Types





Commercial HVAC 101

Section 3: Component Cleaning

AHU Types

Rooftop Unit (RTU)
Packaged Unitary Equipment





Commercial HVAC 101

Section 3: Component Cleaning

AHU Types

Rooftop Unit (RTU)
Packaged Unitary Equipment

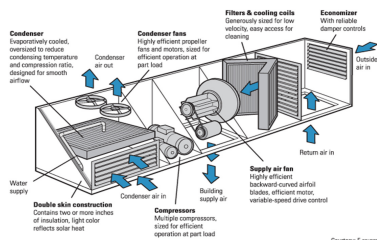

Courtesy: E source



Here's a Tip...

Commercial HVAC 101

Section 3: Component Cleaning

AHU

- ✓ Clean all AHU internal surfaces, components, condensate collectors & drains.
- ✓ Assume that suitable operative drainage system is in place prior to beginning wash down procedures.
- ✓ Clean all coils and related components, including evaporator fins.



TECHNICAL
NADCA
CONFERENCE

Commercial HVAC 101

Section 3: Component Cleaning

Fan Types

Forward Curved fans transfer large volumes of air for a minimum wheel diameter. They're used when space requirements are a primary consideration.

- Blades commonly lose **balance clips**.
- Are by far the **most common** and are in **most residential units**

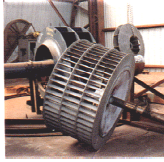

TECHNICAL
NADCA
CONFERENCE

Commercial HVAC 101

Section 3: Component Cleaning

Fan Types

Backward Inclined Flat fan has some of the characteristics of the airfoil fan. Has relatively high efficiency.



A backward inclined fan has a non-overloading characteristic.

The horsepower required by the fan actually decreases when the flow rate increases past a certain point.

TECHNICAL
NADCA
CONFERENCE

Commercial HVAC 101

Section 3: Component Cleaning

Fan Types

Axial fans are suitable for large quantities of air at low pressures.

- Produce very little noise
- Found in return air ducts.

When compared with centrifugal fans, the axial fans are the easiest to clean, but can easily become unbalanced while cleaning.



TECHNICAL
NADCA
CONFERENCE

Commercial HVAC 101

Section 3: Component Cleaning
Fan Cleaning



Sometimes the only way to clean is to go inside!

TECHNICAL
NADCA
CONFERENCE

Commercial HVAC 101

Section 3: Component Cleaning
Coils

- ✓ Reheat coils – Evaporator coils – Condensing coils
- ✓ Heating and cooling coils are placed in the airstream to regulate the temperature of the air delivered to the space
- ✓ In general, the copper rows determine the coil depth for cleaning
- ✓ Not all coils are cleanable
- ✓ When cleaning electrical resistance coils in a duct system, it's important to make sure the power source is de-energized!



TECHNICAL
NADCA
CONFERENCE

Commercial HVAC 101

Section 3: Component Cleaning
Coils

All portions of each coil assembly must be cleaned.

- Both upstream and downstream sides of each coil section shall be accessed for cleaning.
- When both sides of a coil are not accessible for cleaning then removal and/or replacement may be required.
- Visual inspection of the coil and drain pan will determine whether Type 1 or Type 2 cleaning is required.



TECHNICAL NADCA CONFERENCE

Commercial HVAC 101

Section 3: Component Cleaning

Coils

The substances impacted on the evaporator coil help determine the initial cleaning protocol. Evaporator coil cleaning is broken into two (2) categories known as Types. Evaporator coil reconditioning will utilize Type-1 or Type-2 cleaning methods.

Type 1
(Dry Cleaning)

Type 2
(Wet Cleaning)



TECHNICAL NADCA CONFERENCE

Commercial HVAC 101

Section 3: Component Cleaning

Inline Coils

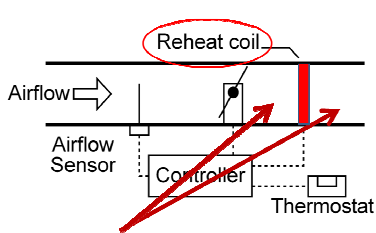

Install Service Openings

TECHNICAL NADCA CONFERENCE

Commercial HVAC 101

Section 3: Component Cleaning

Reheat Coils

Reheat Coils:

- ✓ Need access on both sides
- ✓ No condensate drain
- ✓ Need to set up water control

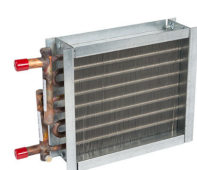

TECHNICAL NADCA CONFERENCE

Commercial HVAC 101

Section 3: Component Cleaning

Drain Lines & Pans

The condensate drain pan and drain line shall be cleaned and flushed. The condensate drain pan shall be inspected to verify proper drainage operation before and after cleaning.



Usually a drain pan and line have the highest amounts of contamination when compared to all other system components.



TECHNICAL NADCA CONFERENCE

Commercial HVAC 101

Section 3: Component Cleaning

VAV/Mixing Box

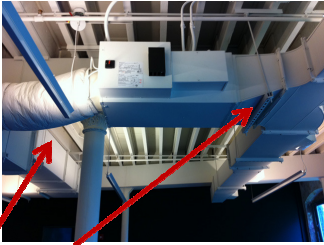

Install Service Opening

TECHNICAL NADCA CONFERENCE

Commercial HVAC 101

Section 3: Component Cleaning

VAV/Mixing Box



Dirty VAV

Clean VAV

TECHNICAL NADCA CONFERENCE

Commercial HVAC 101

Section 3: Component Cleaning

VAV/Mixing Box

- ✓ Electric Coil – be sure to disconnect power & follow Lock Out/Tag Out
- ✓ Pay attention to fiberglass insulation inside of component

TECHNICAL NADCA CONFERENCE

Commercial HVAC 101

Section 3: Component Cleaning

VAV/Mixing Box

Install Service Openings

TECHNICAL NADCA CONFERENCE

Commercial HVAC 101

Section 3: Component Cleaning

Sound Attenuators

Designed to reduce noise in the ducts.

A water pressure washer should not be used for cleaning a perforated sound attenuator and the internal components of perforated sound attenuators are not cleanable.

TECHNICAL
NADCA
CONFERENCE

Commercial HVAC 101

Section 3: Component Cleaning

Turning Vanes



- ✓ Primary function is to reduce static pressure loss in a duct system
- ✓ Require multiple access points and care in cleaning
- ✓ Fiberglass vanes can be very fragile
- ✓ Rarely found in high pressure systems

TECHNICAL
NADCA
CONFERENCE

Commercial HVAC 101

Section 3: Component Cleaning

Turning Vanes

Service Openings

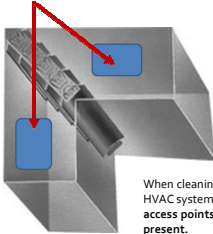

When cleaning a 90-degree turn in a commercial HVAC system, it is recommended to put two (2) access points per turn when turning vanes are present.

TECHNICAL
NADCA
CONFERENCE

Commercial HVAC 101

Section 3: Component Cleaning

Sensors

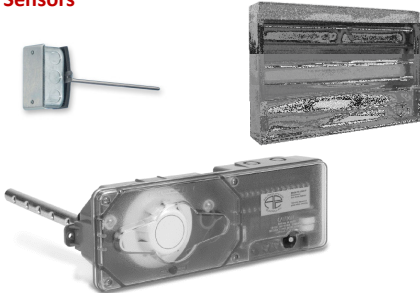

TECHNICAL
NADCA
CONFERENCE

Commercial HVAC 101

Section 3: Component Cleaning
Vents, Grills, Registers & Diffusers

Air distribution devices (registers, grilles & diffusers):

- Remove, if possible, for proper cleaning
- Make sure they are restored to their previous position.



TECHNICAL
NADCA
CONFERENCE

Commercial HVAC 101

Section 3: Component Cleaning
Slot Diffusers

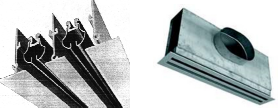

- Not easily removed
- Rubber bladder
- Air wash

Most of these are connected to the ceiling or ceiling grid.

Here's a Tip...
Always check the inside of these for damaged or friable insulation.

TECHNICAL
NADCA
CONFERENCE

Commercial HVAC 101

Section 3: Component Cleaning
Sheet Metal Ducts With Insulation



- Microbial issues
- Reasons for insulation in duct
- Coatings

Here's a Tip...
If you can't properly clean it, you can't coat it!

TECHNICAL NADCA CONFERENCE

Commercial HVAC 101

Section 3: Component Cleaning

Duct Board

- Microbial issues
- Reasons for using this type
- Coatings



Here's a Tip... If you can't properly clean it, you can't coat it!

Be sure to use mechanical cleaning methods that will not create abrasions, breaks, or tears to fibrous glass liner or duct board surfaces!

TECHNICAL NADCA CONFERENCE

Commercial HVAC 101

Section 3: Component Cleaning

Externally Insulated Duct

- Reasons for insulation
- Thermal value only
- Carefully create access
- Reinstall insulation after access openings are made.



TECHNICAL NADCA CONFERENCE

Commercial HVAC 101

Section 3: Component Cleaning

Fiberglass and Insulated Duct Work

Thoroughly clean with HEPA vacuuming equipment, while system is under constant negative pressure.

Do not get fibrous glass components wet

Do not cause damage to fibrous glass components

TECHNICAL NADCA CONFERENCE

Commercial HVAC 101

Section 3: Component Cleaning
Fiberglass and Insulated Duct Work

Here's a Tip...

When physically entering lined ductwork, caution must be taken not to damage the lining.



Component Cleaning

Q&A

You have Questions
We have Answers

TECHNICAL NADCA CONFERENCE

Commercial HVAC 101

Section 4: Standards

HVAC System Cleaning Requirements

- Visibility Clean
- Source Removal
- Negative Duct Pressurization
- Service Openings
- Containment





TECHNICAL NADCA CONFERENCE

Commercial HVAC 101

Section 4: Standards

Selecting the HVAC cleaning method to be employed on any given project is an important factor for successful cleaning.

- Vacuum Collection
- Brushing
- Air Washing
- Hand or Contact Vacuuming
- Hand Washing
- Power Washing

TECHNICAL NADCA CONFERENCE

Commercial HVAC 101

Section 4: Standards

Visibly Clean Standard

Key Terms

Visibly Clean:
An interior surface is considered visibly clean when it is free from **"non-adhered"** substances and debris.

Definition: What does non-adhered mean?
Any material not intended or designed to be present in an HVAC system, and which can be removed by contact vacuuming.



TECHNICAL NADCA CONFERENCE

Commercial HVAC 101

Section 4: Standards

Source Removal

Key Terms

Source Removal
The mechanical cleaning of system components to remove dirt and debris.

Requires two key elements to be effective:

- Agitation** of dust and debris within the HVAC system.
- Extraction** of contaminants from the HVAC system

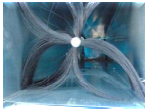

TECHNICAL
NADCA
CONFERENCE

Commercial
HVAC 101

**Section 4:
Cleaning Requirements & Standards**

Negative Duct Pressurization

Key Terms

Negative Pressure
Used to prevent debris from entering the occupied space or leaving the contained area.

Prior to and throughout the duration of the cleaning process, the HVAC system and associated air duct *shall* be kept at an appropriate negative pressure differential relative to the indoor non-work area.



TECHNICAL
NADCA
CONFERENCE

Commercial
HVAC 101

**Section 4:
Cleaning Requirements & Standards**

Effective negative pressure containment requires:

- Physical barrier around work area
- Sealing off HVAC return air grills
- Continuously pulling air through a HEPA filtration device to reduce airborne particles.
- Exhausting more cubic feet per minute of clean, HEPA-filtered air out of the space than is supplied into it.

TECHNICAL
NADCA
CONFERENCE

Commercial
HVAC 101



**Section 4:
Cleaning Requirements & Standards**

Service Openings

Minimum Requirements for Service Openings

Service openings shall:

- not degrade the structural, thermal, or functional integrity of the system;
- not hinder, restrict, or alter the airflow within the air duct;
- not be made in flexible ductwork;
- be created in a manner that allows for proper closure;
- comply with applicable UL, SMACNA and NFPA standards, as well as local, regional, state and federal codes.



Commercial HVAC 101

Section 4: Cleaning Requirements & Standards

Service Openings

Service Panels

- Shall be of an equivalent gauge or heavier
- Shall be mechanically fastened (screwed or riveted) at minimum every 4" on center.
- Shall overlap the ductwork surfaces by a minimum of 2" on all sides.
- Recommended to be sealed with gaskets, duct sealants, mastic or tape.





Commercial HVAC 101

Section 4: Cleaning Requirements & Standards

Containment





Commercial HVAC 101

Section 4: Cleaning Requirements & Standards

Containment



TECHNICAL
NADCA
CONFERENCE

Commercial
HVAC 101

Section 4:
Cleaning Requirements & Standards

Containment



09/12/2016 02:04

09/12/2016 02:08

TECHNICAL
NADCA
CONFERENCE

Commercial
HVAC 101

Section 4:
Cleaning Requirements & Standards

Containment



09/20/2016 11:33

Commercial
HVAC 101

Q&A

You have
Questions

We have
Answers



Commercial
HVAC 101

Presenter Contact Information

- Robert Rizen
- Robert.rizen@gmail.com
- 314-518-1681

Thank you
for
Participating!

